



Powerflex 15 High Performance Hose Pumps

Features and Benefits

- Can run dry continuously
- Most suitable for handling shear sensitive products
- Accurate (+1%) dosing (metering) capabilities
- Smooth liquid passage without valves, dead corners, or glands
- The material to be pumped does not contact mechanical parts of seals
- Easy maintenance, low cost, short down time
- Only one wearing part: the hose
- Easily and completely cleanable
- Easily adjustable and reversible rotation
- Suitable for high viscosity and densities
- No metal contact or valves
- Safe for use in explosive environments
- No internal back flow (slip)
- Designed to pump liquids containing particles (abrasion is no restriction)
- Self priming to 95% vacuum
- Direct coupled design to do easy service and save space
- Ultra compact footprint with flanged planetary gearing: no coupling or drive alignment required
- Three year comprehensive warranty

PF 15 Performance Chart

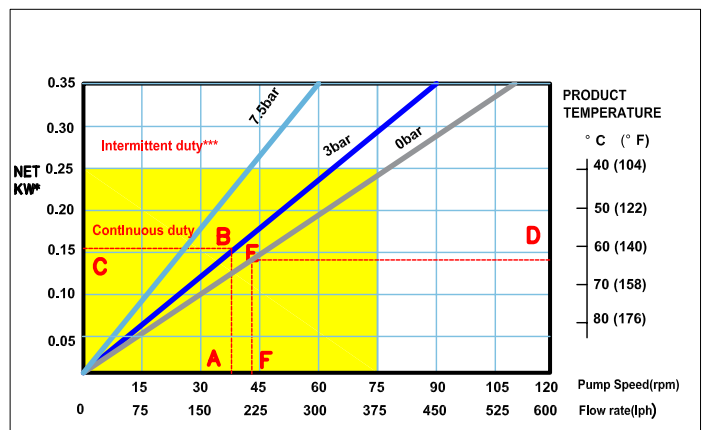

How to calculate speed/horsepower

- A - Flow required, indicates pump speed
- B - Calculated discharge pressure
- C - Horsepower required
- D - Fluid temperature
- E - Calculated discharge pressure
- F - Maximum recommended pump speed**

* Minimum starting torque 60N.M based on starting unloaded at atmospheric discharge pressure. Starting torque can be 2-3X running torque if starting under the load of higher discharge pressures.

** For maximum hose life, speed point (A) should be lower than temperature adjusted speed point (F). See example points (A) thru (F). ***Intermittent duty = 2 hrs max continuous running, 1 hr stop before restart.

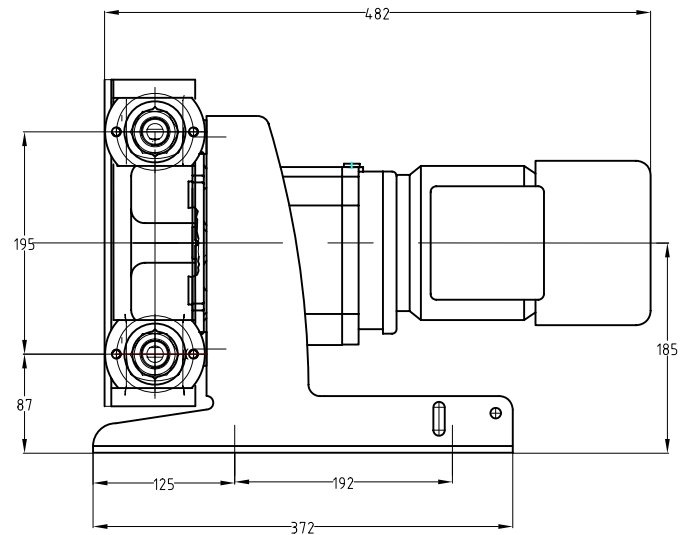
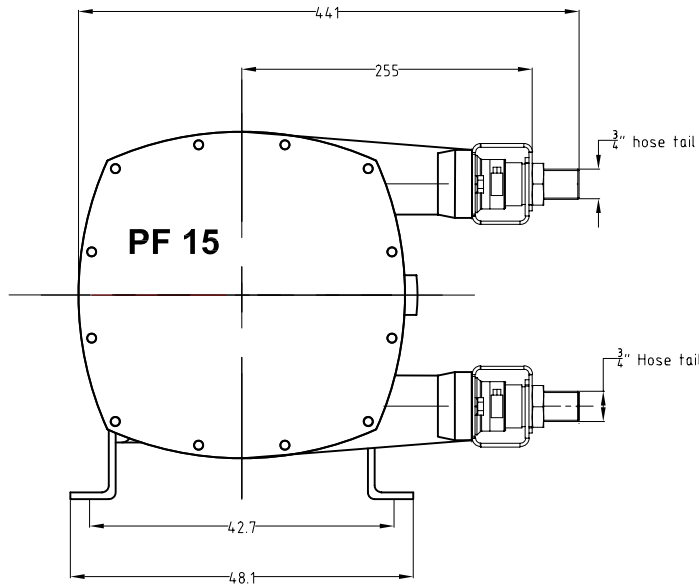

PF 15 High Performance Hose Pumps

Technical Specification

- Displacement: 0.083l/rev
- Supply: 220V/380V 3-phase
- Operating Speeds: Up to 90 rpm continuous
- Up to 120 rpm intermittent
- Fluid Temperature Range*: -10° to 80° C
- Ambient Temperature Range**: -20° to 45° C
- Hose Lubricant Required: 0.5L
- Flow Range: Up to 600L/H
- Discharge Pressure: Up to 7.5Bar
- Suction Pressure: 9M lift to 3bar
- Hose Materials: Natural Rubber, Buna N, EPDM, Hypalon, Bioprene***
- Fittings: DN15 PN16 Flange or hose tail
- Insert Materials: 316SS, Polypropylene, PVC, PVDF
- Optional High Level Hose Leak Sensor: NO or NC: 1A max, 250V max, 50VA max

When installing, allow min 1M linear clearance from ports to facilitate hose changing

Material of Construction

Despecification	Material	Weight(kg)	Paint
Pump housing	Cast iron GG25	18Kg	RAL3011
Front Cover	Mild Steel	0.5Kg	Black
Rotor	Cast Iron	6Kg	-
	Aluminium	2Kg	-
Flanges	Galvanized steel, 304SS or 316SS		
Flange Brackets	Galvanized steel, 316SS	0.4Kg	
Insert	Galvanized steel, 304SS or 316SS	3Kg	
Support Frame	Zinc plated steel or 316SS		
Hardware	Galvanized steel		
Hose Clamps	NR,NBR,EPDM	0.75Kg	
Hose	Speical Compound glycerine	0.5L	
Lubricant			
Pump Unit without drive		35Kg	

The information contained in this document is believed to be correct, but Endura-varp Pumps accepts no liability for any errors it contains, and reserves the right to alter specifications without notice